

Sealing Frames to Structure

TDS96/120624

Sealing Between Fire Resisting Door Assemblies and the Surrounding Structure

In order to maintain the fire resistance and smoke control of a door assembly, the junction between the door frame and the surrounding structure should be adequately sealed. The following are the approved details from section 9.4 tables 2 to 5 of BS: 8214: 2016.

The structural opening for the door assembly should be prepared to a size including any permissible clearance. Under no circumstances should gaps between the door frame and structure exceed 20mm.

The main supporting structure (the wall or partition) for the door assembly should be subject to a fire resistance test and should be shown to be capable of supporting the proposed door assembly for the required fire resistance period.

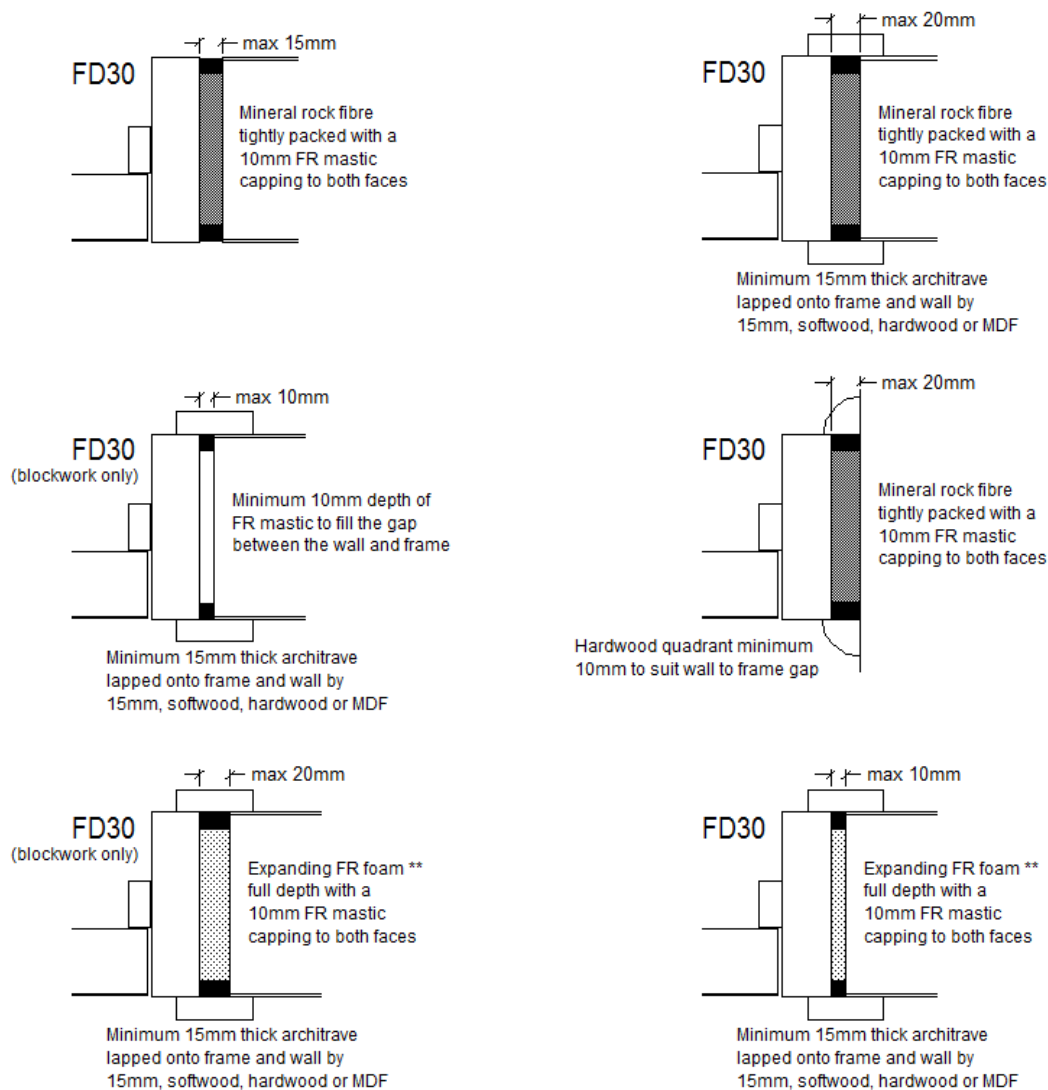

** Restricted to the use of expanding foam that has been successfully tested to BS 476 Part 22 or BS EN 1634-1 for a period of 30 minute fire resistance. Always refer to the foam manufacturer’s test evidence and instructions as this could limit the types of surrounding structure.

David Smith St Ives Limited

Registered in England No: 914878

Marley Road t: 01480 309900
 St Ives
 Huntingdon e: info@davidsmith.co.uk
 Cambs | PE27 3EX w: www.davidsmith.co.uk

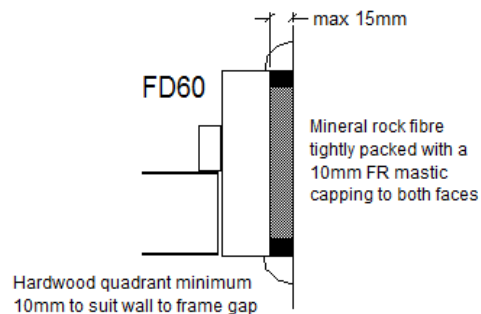
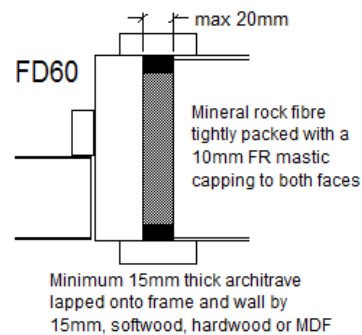
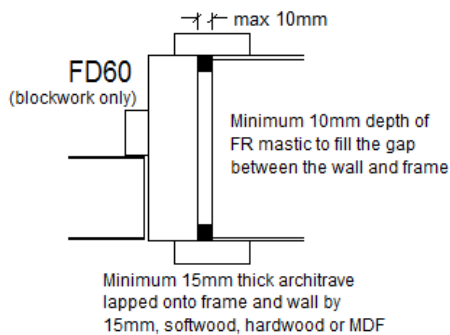
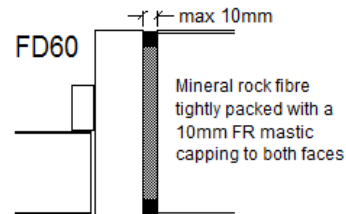
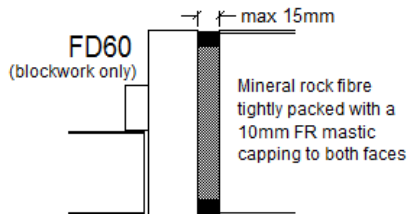

BS 8214:2016 refers to the supporting structure as being 'unlikely or likely to exhibit significant distortion during fire exposure'. For example 'unlikely' would be masonry or non-loadbearing timber stud walls and 'likely' would be steel stud or load bearing timber stud walls.

Where denoted as (blockwork only) above, this would include masonry or non-loadbearing timber stud walls.

BS 8214:2016 does not provide details for the use of expanding foam for 60 minute applications and therefore is not compliant with the standard. For further advice on expanding foam please refer to our technical data sheet No. 202.

The use of glass fibre or glass wool is not an acceptable alternative to the tightly packed mineral rock fibre requirement.

Where architraves are relied on as part of the seal arrangement they should be mechanically fixed. In instances where architraves are fixed with adhesive the sealing method should be one that does not rely on the architrave.

David Smith St Ives Limited

Registered in England No: 914878

Marley Road t: 01480 309900

St Ives

Huntingdon e: info@davidsmith.co.uk

Cambs | PE27 3EX w: www.davidsmith.co.uk