

technical data sheet – No.095

DS Screen Installation Guidance

TDS095/140122

The DS Screen range is an extensive modular system developed to be used with the DS ranges of doorsets. It is an all timber construction featuring glass from market leaders AGC, Pilkington and Pyroguard. The glazed screens can be stand-alone items with single or multiple panes or can be joined to other screens or doorsets to form combination screens.

This guide is focused around the installation of DS performance screens, in particular glazed screens with and without doorsets that are fire resistant. For consistency our recommendation is to use this guidance for all screens supplied by David Smith Limited.

Building Regulations recognise that independent Third Party Certification schemes are an effective means of providing assurance of quality, reliability and safety. DS Screens (and Doorsets) are designed and manufactured under IFC Third Party Certification and should be installed by a Third Party accredited contractor.

Before attempting installation make sure that a full set of our drawings and schedules are made available to the fixing team to help with identification, fixing and glazing.

The screens, and probably doorsets, will arrive on site palletised for mechanical offloading and will be protected against in-transit damage. It is important that all components are checked at the time of delivery and any observations are reported within 24 hours.

Should you need to contact us about an individual screen please refer to the details from the label or If you have an app on your smartphone, scan the barcode and forward that to us.

The screens have been produced in a temperature and humidity controlled factory to condition them for the environment in which they will be used. We aim for a product moisture content of between 9-14%. Providing they are kept and installed in a controlled environment they will maintain stability and perform as they should. Please read our On Site Storage, Care and Handling information for more details.

Delivery and installation should take place after wet trades have been completed and the building has returned to acceptable relative humidity levels, the screens and doorsets are designed and manufactured as a second/third fix item.

Delivery of screens will be pre-arranged and each item will be individually listed on our advice notes. Any loose items that need fitting on site will be boxed or bagged separately and will be accompanied by a packing check list.

Larger screens will be supplied disassembled, packed as a kit and palletised with other products. This reduces the risk of injury from manual handling large assembled units and allows easier distribute to the required location. These frames will have been trial assembled, dismantled and bundled as a kit for easy on site assembly with a screwdriver.

Each screen will be identified by a unique number, usually designated by the building designer. The number identified by a product label on the top of the screen can be used to locate the screen on the floor plan.

Glass for the screens will be delivered separately by our specialist partner. Each pane will be identified to the screen and to the opening if there are multiple panes.

To prevent injuries when lifting these heavy items it is important to recognise the weights from the delivery documents or the product labels and use your company Health and Safety manual handling procedures.

Directly after installation, it is essential that the screens and glass are protected from being damaged by other trades. The level of protection is the contractors responsibility. Substantial protection would be required to protect against heavier mistreatment, be careful with adhesive tape as it could leave residue or it could react with the finish on the timber.

Installation

The screens can be installed in supporting constructions of timber or steel stud plasterboard partitions, blockwork, brickwork or concrete walls. Where fire rated, timber or steel stud partitions should be subject to fire resistance test and should be shown to be capable of supporting screens and doorset assemblies for the required fire resistance period.

Where screens are installed into timber or metal stud partitioning, the opening should be lined between the plasterboard with timber that is of a sufficient thickness to accept the minimum penetration of the frame fixing screws, at least 40mm. In steel stud partitioning the timber stud can be positioned inside the perimeter steel stud.

Before starting the installation it is advisable to check that the wall opening is plumb and square and the correct size for the screen. The gap between the frame and structure should not be less than 5mm and no more than 20mm for fire and smoke control.

It is important to note that screens must be securely fixed to the supporting structure at all four edges, head, jambs and cill.

Once you are satisfied that the wall opening and screen sizes are correct, installation can begin by offering the frame into the opening, pack and temporarily fix one side of the screen plumb to the wall. At this point it may be preferable to remove the glazing beads from the screen to access fixing positions. Make sure the beads are kept safe and identified for the glazing process.

With the screen central in the opening, level the head and position the second jamb so that it is plumb and parallel to the first. Pack behind the frame jamb and temporarily fix with two fixings.

DS Screen Installation Guidance

TDS095/140122

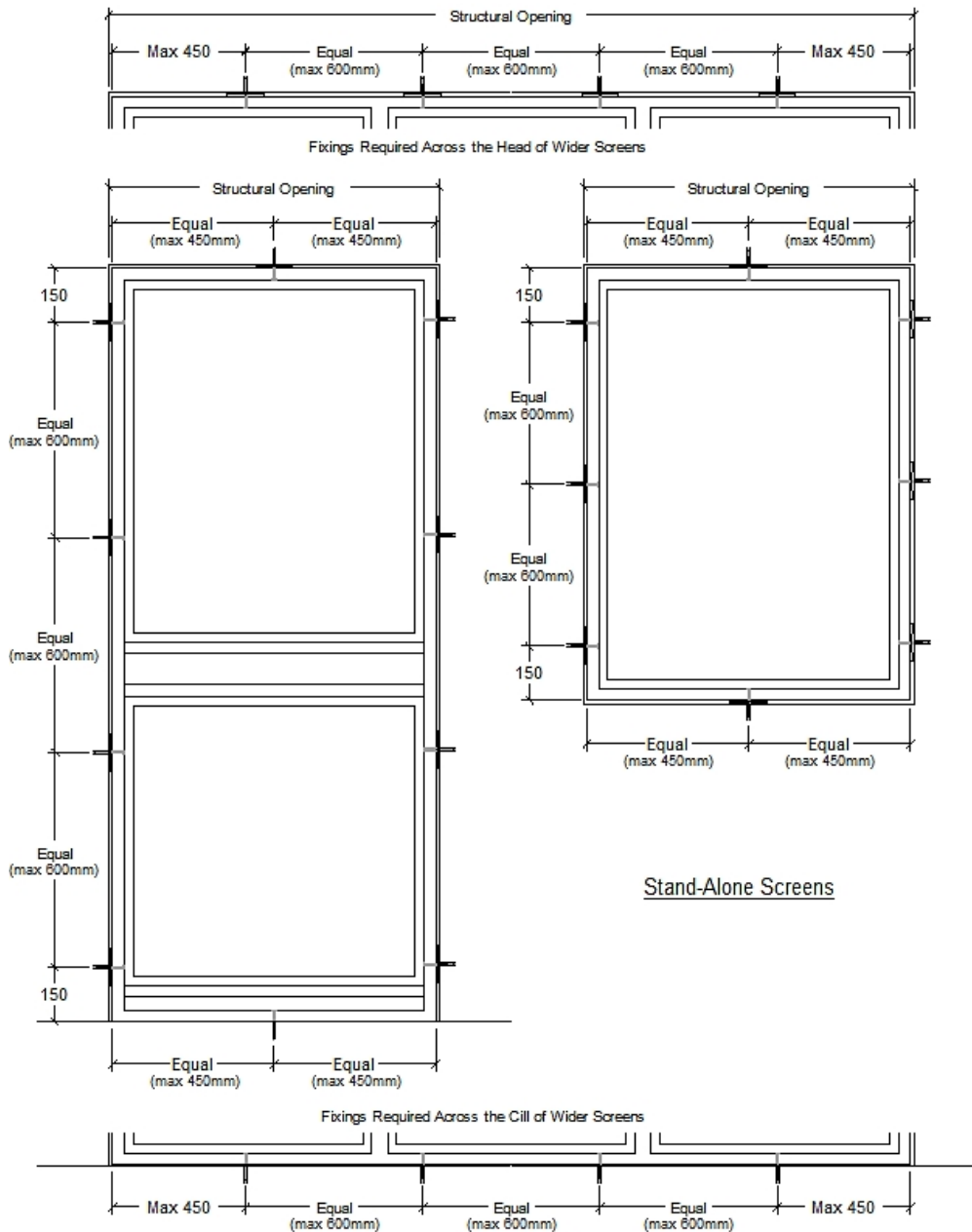

Fixings positions for the jambs should be 150mm from each end and at no more than 600mm centres. At the head and cill the fixings should be at a maximum of 450mm from each end and at no more than 600mm centres.

Where a larger upstand obstructs the lower fixing point, the position can be increased to a maximum 200mm from the base of the frame.

Keep the fixing points a minimum 35mm away from the wall or partition face to prevent breakout. Wider frames may need a double row of fixings positioned in pairs at the same fixing points. Wherever possible hide the head of the fixings under stops or beads, otherwise counterbore and pellet over the fixings.

Each fixing point must be properly packed with timber, hardwood for FD60, plywood or similar to provide a solid localized bearing between the structural opening and the back of the frame. If combustible packers, such as plastic wedges, are used they must be protected by a 10mm deep capping of fire resistant mastic to both faces.

The mechanical fixings can be proprietary types suitable for door frame installation into the specific wall construction. Steel screws of 5mm or 6mm diameter are acceptable but in all cases the fixing must be of sufficient length to penetrate into the wall structure by at least 40mm. In most cases 90mm or 100mm screws can be used, for very heavy door leaves increase the length of the fixings so that penetration into the structure is 60-70mm.

DS Screen Installation Guidance

TDS095/140122

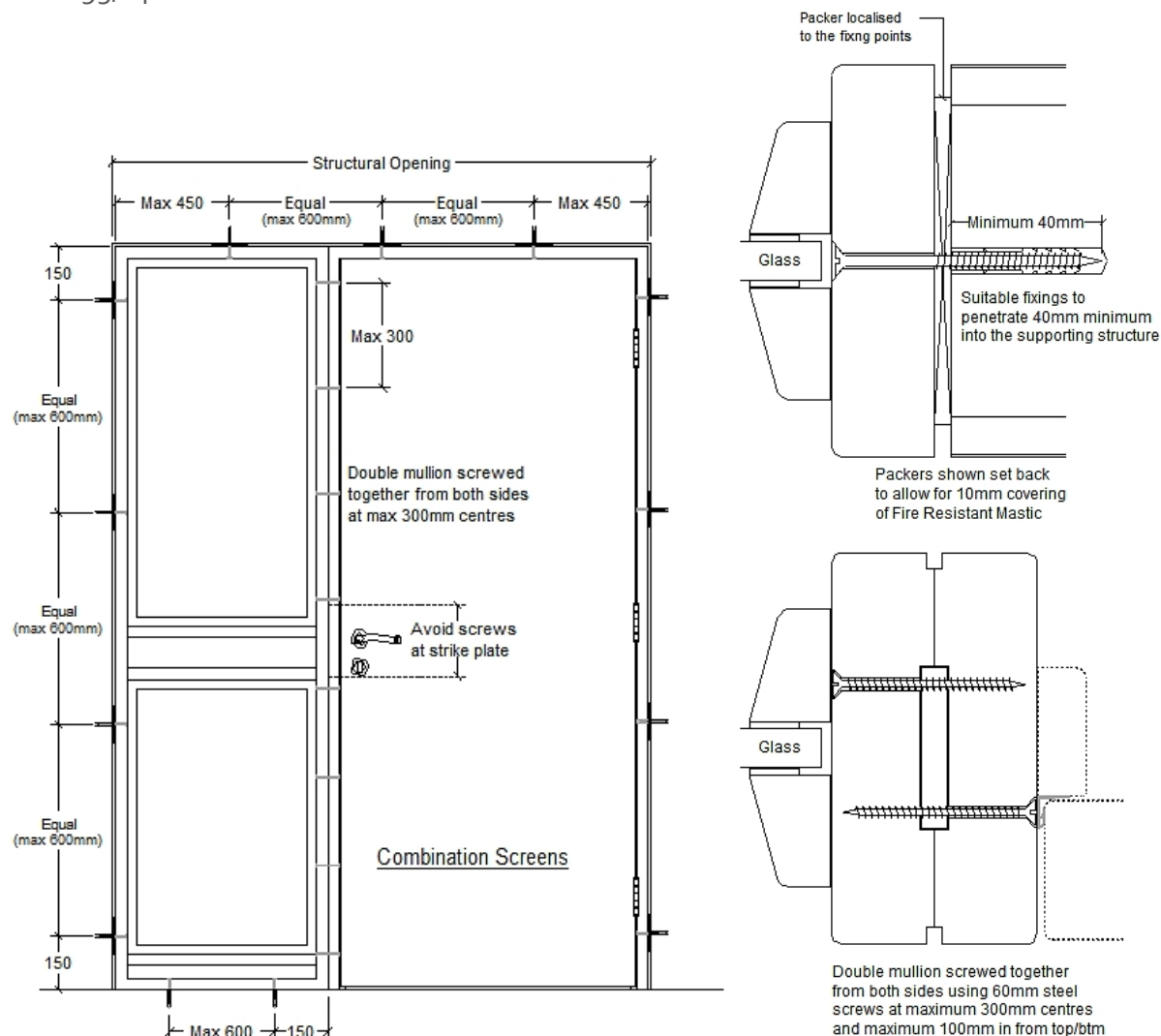

If the screen is part of a doorset combination it is advisable to check the level of the floor screed so that adjustment can be made prior to installation to ensure compliance with threshold gaps, particularly for fire and smoke control. When the installation and finished floor is complete the gap under the door should be no more than 6mm for fire resistance and 3mm for smoke control.

Where applicable, hang the door(s) in the frame and use as a template to even the gaps around all edges. Pack and adjust at the frame fixing points to check and align the frame with the door/s, making sure that there is no twist that would misalign the door(s).

For all other aspects of 'Doorset Installation' refer to Technical Data Sheet No 090.

Sealing the Frames to the Structure

It is very important that the correct fire stopping is used in gaps between the screen and the surrounding structure to maintain fire integrity and smoke control. This must be carried out in accordance with BS: 8214: 2016, Refer to Technical Data Sheet 096 'Sealing Frames to Structure'. The method of sealing is dependent on the wall structure and the use of the correct architrave.

Expanding foam is a popular fire stopping material with installers of fire resistant timber doorsets and glazed screens. Fire Door Foam by Fire and Acoustic Seals Limited has been tested and assessed for use with Timber Glazed Screens. For full details, refer to Technical Data Sheet 202 'The Use of Fire Resistant Expanding Foam'.

Where architraves are relied on as part of the fire stopping arrangement they should be mechanically fixed. In instances where architraves are fixed with adhesive the method should be one that does not rely on the architrave.

Sealing between the frame and wall is also important for sound transmittance and should be considered in the same way as fire stopping even where screens may not be fire resistant.

DS Screen Installation Guidance

TDS095/140122

Glazing Screens

Once the screen is fixed securely into the structure it is ready to glaze with the appropriate glass supplied. Contract drawings and schedules will have been issued to show the glass type and the method of fixing.

Glazing beads will have been supplied mitred and temporarily fixed in position with a minimal number of pins or screws. The temporary pins are not part of the glazing system and should be removed in preparation for the specified arrangement. The required glazing seals will be supplied fitted to the glazing beads.

Essentially there are two types of glazing bead, bevelled and square, both can be fixed with pins or screws but for 60 minute performance the beads must be screw fixed.

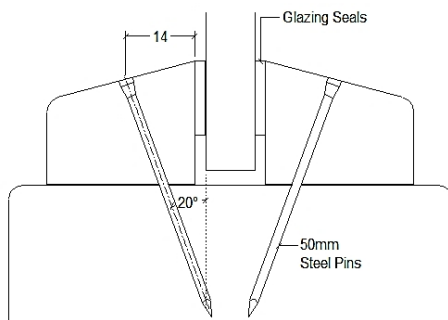

Bevelled Beads Pinned (FR30)

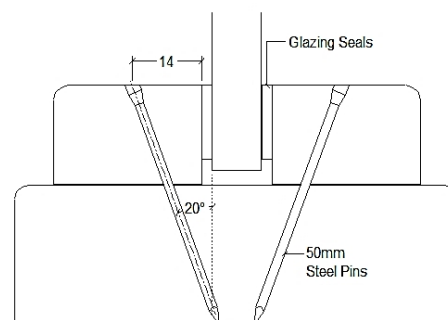

Square Beads Pinned (FR30)

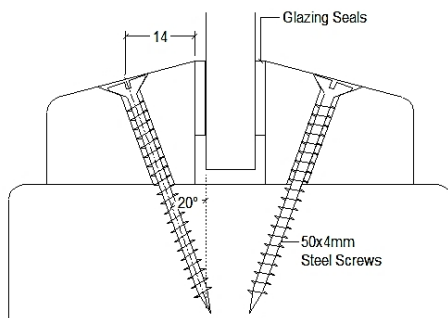

Bevelled Beads Screwed (FR30 or FR60)

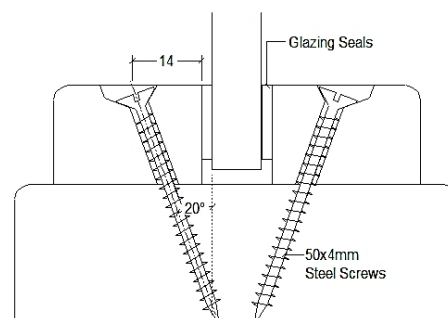

Square Beads Screwed (FR30 or FR60)

Check the actual thickness of the glass as the manufacturing tolerance can be especially high on the thicker glass types. Fix one set of the beads with the exposed face of the glazing seal off centre in the frame by half the glass thickness. (There are occasions where the glass is installed off centre in the screen, in which case you must follow the contract specific drawings).

Where beads are pin fixed, 50mm steel pins (not supplied) must be inserted at maximum 150mm centres, maximum 50mm from the corners, 14mm from the glass edge and at a 20 degree angle to the plane of the glass (20 degrees from vertical).

Where beads are to be screw fixed they will have been supplied pre-drilled at the correct centres and angle, and the 50x4mm steel screws will be supplied loose.

If the glazing beads are exceptionally wide in section, usually where the bead is extended to finish flush with the frame edge, a second row of fixings can be added at the installers discretion. The essential row of mechanical fixings must still be positioned 14mm from the glazing seal edge of the beads.

Before attempting to install the glass in the screen make sure that the first set of beads have been properly fixed and be aware of the weight of the glass to be installed, the glass weight will be shown on the contract drawings. Refer to your company manual handling procedures for lifting heavy objects and your health and safety procedures for handling glass.

When offering the glass into the opening there will be a 3-5mm expansion gap around the glass edge. Hardwood setting blocks 3-5mm thick (not supplied) should be used along the bottom edge and one side to centre the glass and maintain an equal gap around all four edges.

If the screen has an acoustic requirement, it is advisable to bed the edge of the glass on acrylic intumescent acoustic mastic to form a seal between the glass, frame and bead.

With the glass temporarily held in position repeat the glazing bead fixing on the second side. For aesthetics pins can be punched under the surface and filled over, screws are generally left as seen.